

2

All kinds of families

Lesson 1 → Vocabulary

Let's review!

PB p10-11

Find and trace. Then say.

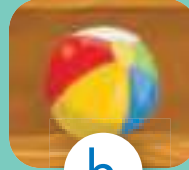

b

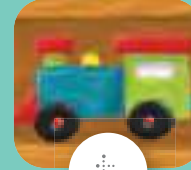

t

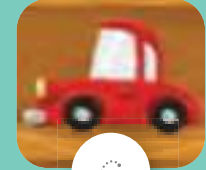

c

1 Trace and match.

brother

sister

mum

dad

granny

grandad

auntie

uncle



Tell me!

Look at my new words. Match and colour.

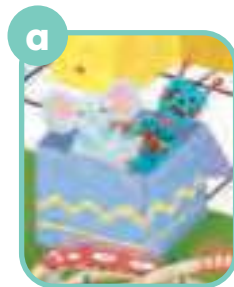

Toys

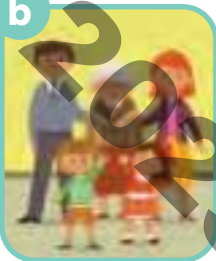

Family

Lesson 2 → Structures

1  Listen and match.

This is my family.

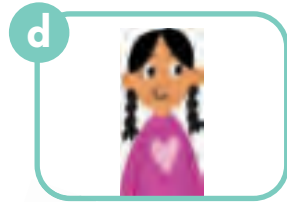

2 Read. Then look at Activity 1 and number.

This is my granny, my grandad and my sister.



This is my mum, my dad and my brother.

I can shine!

3  Draw someone in your family. Write. Then tell a friend.

This is my _____.



colour me



Write your favourite family word. _____

Extra time?

Lesson 3 → Story

1

PB p22-23

Who is in Bruno's family? Look and tick (✓).

1



2



3



2

Follow. Then circle.



Let's imagine!

I've got a brother / an auntie.

I can shine!

3



Draw.
Then say.

And you?
Who's in your
family?

colour me



Lesson 4 → Vocabulary and structures

1 Read and trace. Then circle.



1

I've got a
dog / bird.

2

I've got a
cat / bird.

3

I've got a
fish / cat.

2 Match and say.



Let's build!

I've got a brother.

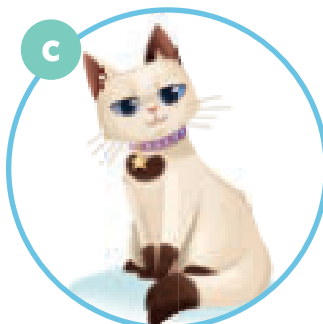
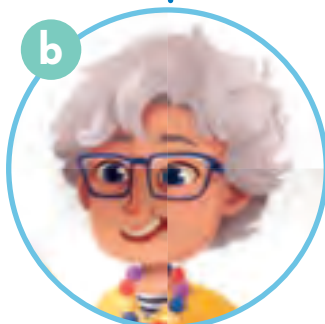

I've got a sister.

I've got a granny.

I've got a cat.

I've got a mum.

Think of a pet for you. Draw and tell a friend.

Extra
time?

Lesson 5 → Communication

1 2.13 Listen and number.



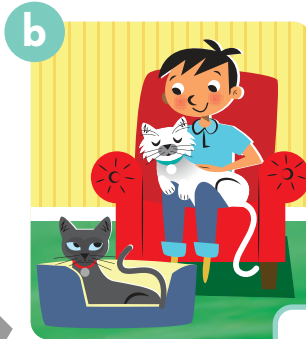



 1

My sounds

2 2.14 Listen and repeat. Trace. Then match.



I can shine!

3 Tick (✓) for you. Then tell a friend.

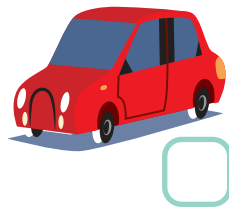
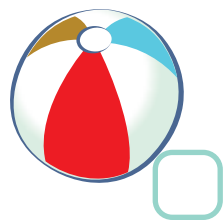
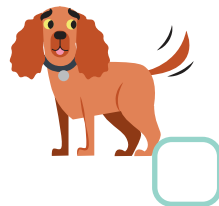

I've got a ...
And you?



1 Read and match. Then say.

*This is for
my cousin.*

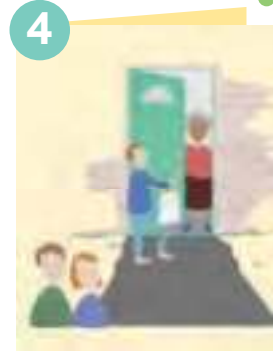
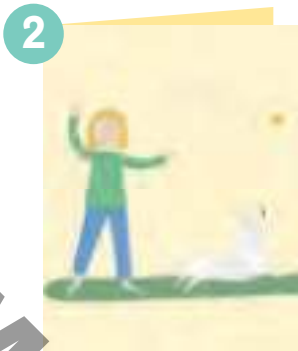

a neighbour

b cousin

c friend

d pet

I can shine!

2 Draw and write.
Then act out.

Think and share
Do you help your
friends and family?

This is for my
_____.



colour me



Who do you help in your family? Tell a friend.

Extra
time?



Lesson 8 → Unit 2 Review

1 Trace. Then number for Dexter.

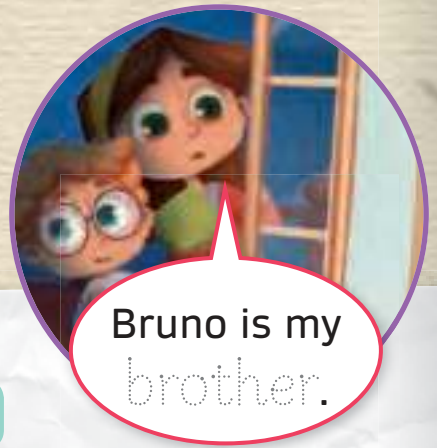





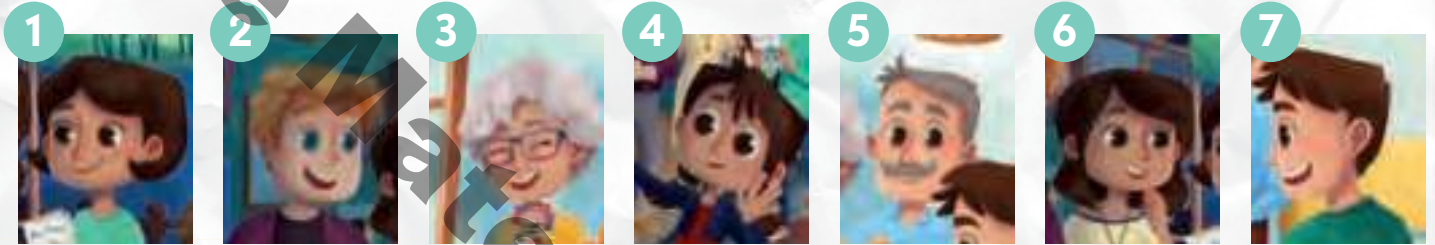

This is my ...

mum. granny. auntie.
 dad. granddad. uncle. sister.



2 Look and read. Tick (✓) or cross (✗) for you. Then tell a friend.

				
1 	✓	✓	✗	✗
2 	✗	✗	✓	✓
3 Me				

I've got a bird and a cat.

I've got a dog and a fish.

3



Stick, draw and colour. Then complete the family tree.

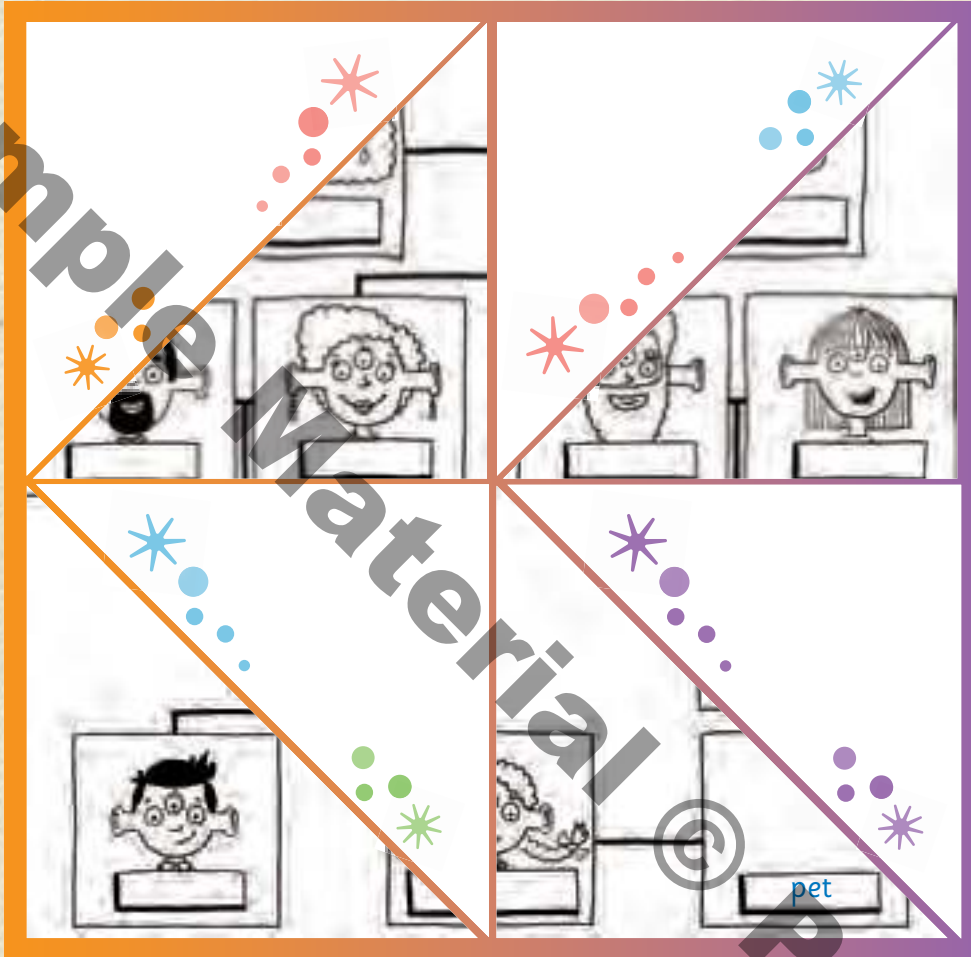

This is my grandad.

I've got a dog.

4

Read. Then think and write.

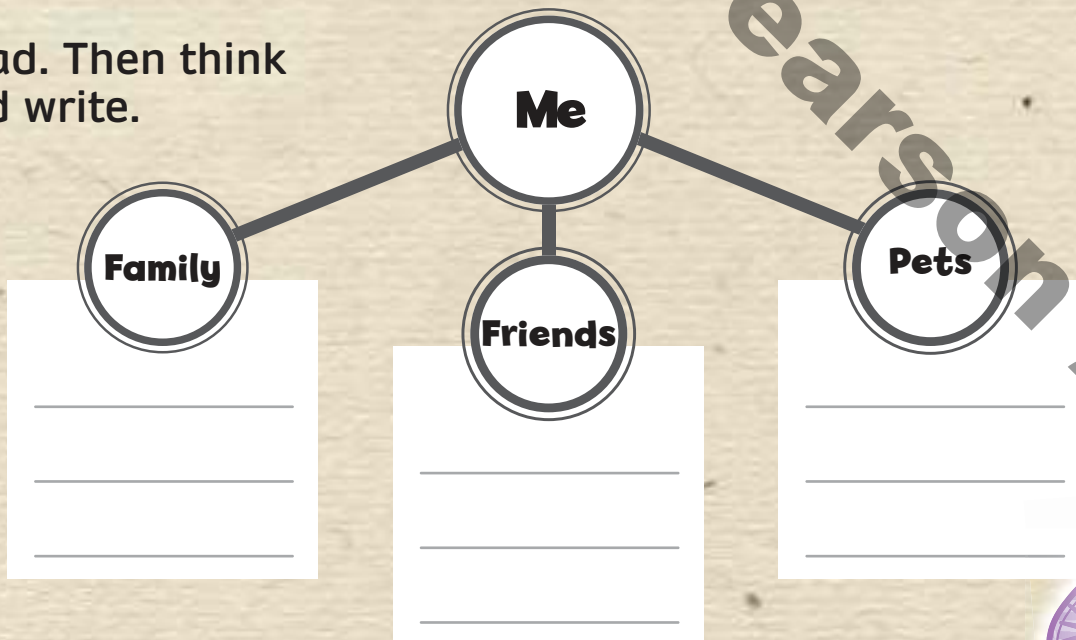

2

Review 1 Important to me

1 Colour and say.

It's a train.

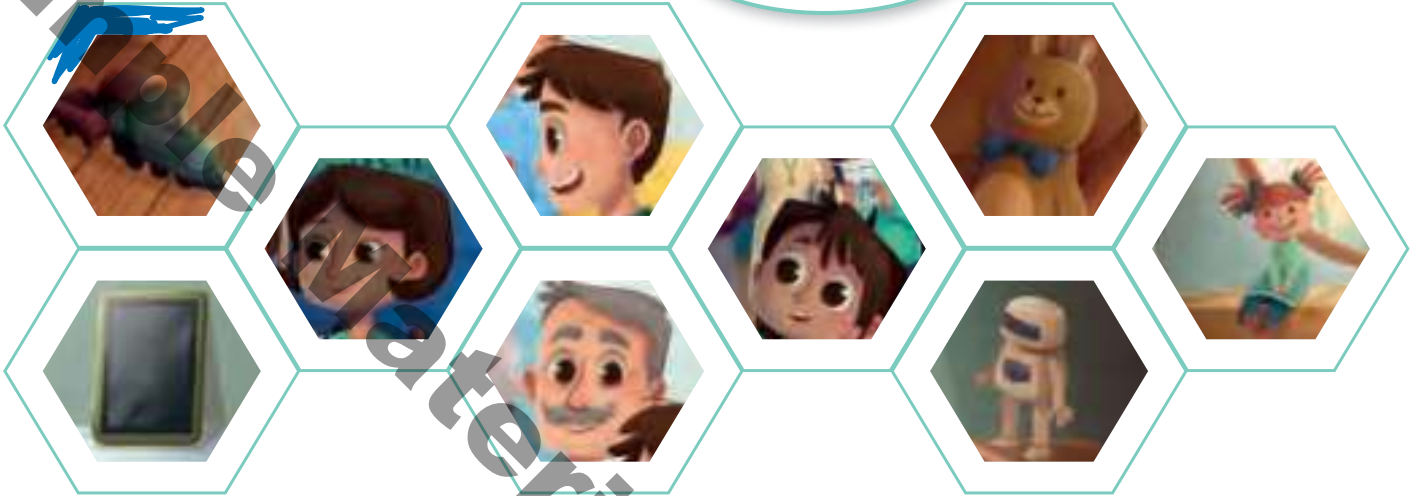

2 Listen and number. Then ask and answer.

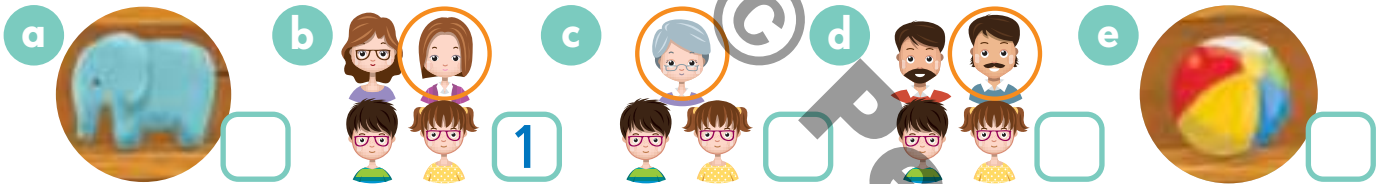

Who's this?

This is my ...

What's this?

It's a ...

3 Join the dots. Then read, trace and circle.

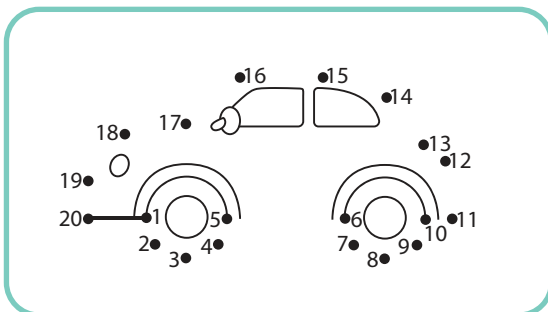

1 It's a train / car.

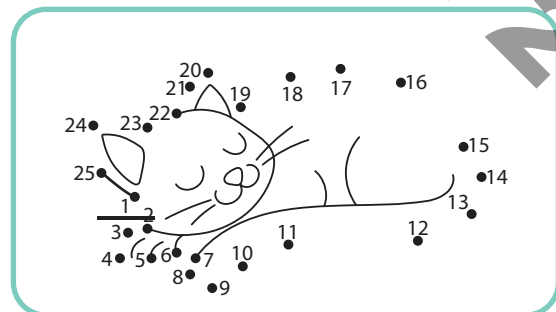

2 This is my cat / dog.

4 Read and trace. Then tick (✓) for you.

I've got ...



a new bike. an old plane. a big dog. a small fish.

5 Think of a toy to play with. Draw, write and say.

Let's play with the _____.



Mini-project

6 Think of a toy to give to your best friend. Draw and write.



This is for you,

_____.

It's a _____.

Time to shine!

7 Read and colour.

- 1 I can write toy words. ✓ ? X
- 2 I can write family words. ✓ ? X
- 3 I can talk about things and people important to me. ✓ ? X
- 4 I completed Review 1! ✓ ? X